

VIKING

LED-Waterproof Luminaire

LED-Feuchtraumleuchte

NORDEON

Installation Instructions · Montageanleitung · Notice de montage · indicaciones de montaje · Istruzioni per l'installazione · Installatie-instructies

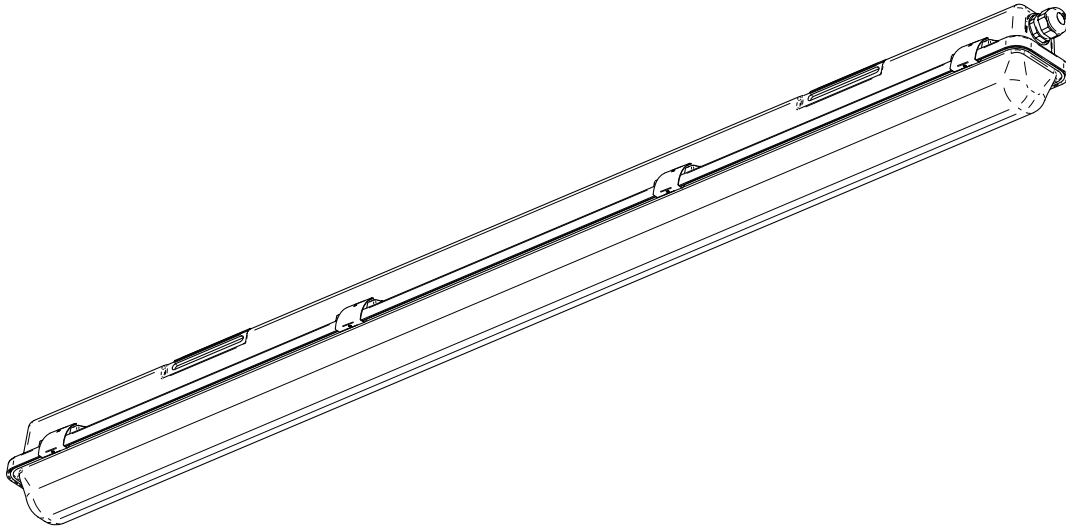

IP65

CL 1



max.
25°C

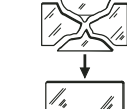
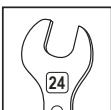
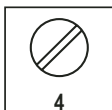

Use luminaires only with complete protection covers!

Die Leuchte darf nur mit ihren vollständigen Schutzabdeckungen betrieben werden!



Luminaire for use in environments where an accumulation of conductive dust on the luminaire may be expected.

Leuchte zur Verwendung in einer Umgebung, in der eine Ablagerung von leitfähigem Staub auf der Leuchte erwartet werden kann.

Nordeon SAS
2 rue L.J Thénard
71 100 Chalon sur saone
03 85 47 67 00

Inrush Current: max. 22 A / 2750 μ s
Einschaltstrom: max. 22 A / 2750 μ s

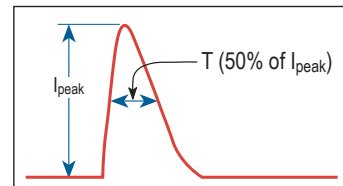

Max. drivers on MCB (16 A type-B): max. 22
Max. Treiber MCB (16 A Typ-B): max. 22



General safety notes Allgemeine Sicherheitshinweise

- GB** -Installation/maintenance only by skilled personnel.
-During overhaul/maintenance only use original parts.
-If any luminaire is subsequently modified, the person responsible for the modification shall be considered the manufacturer.
-The manufacturer bears no liability for damage caused by inappropriate use or application.
-Due to problems with chemical resistance, choose cleaning materials which are suitable for plastic.
- D** -Montage/Wartung nur durch Fachkräfte.
-Bei Instandsetzung/Instandhaltung nur Originalteile verwenden.
-Werden nachträglich Änderungen an Leuchten vorgenommen, so gilt derjenige als Hersteller, der diese Änderung vornimmt.
-Der Hersteller übernimmt keine Haftung für Schäden, die durch unsachgemäßen Einsatz entstehen.
-Chemische Beständigkeit beachten. Nur kunststoffverträgliche Reinigungsmittel verwenden.

Mounting/Montage

1

Variant Ausführung (ca. lm)	Dimensions Abmessungen (mm)			Power Leistung (W)	Weight Gewicht (kg)
	A +/-	B	C		
	30				
2000 lm STD	-*	500	678	20,7	1,5
2000 lm DALI	-*	500	678	21,7	1,5
4000 lm STD	760	880	1234	35,5	2,5
4000 lm DALI	760	880	1234	36,5	2,5
5000 lm STD	1060	1180	1534	40,0	3,1
5000 lm DALI	1060	1180	1534	41,0	3,1

* only direct mounting (regarding B) / nur direkt montierbar (siehe B)

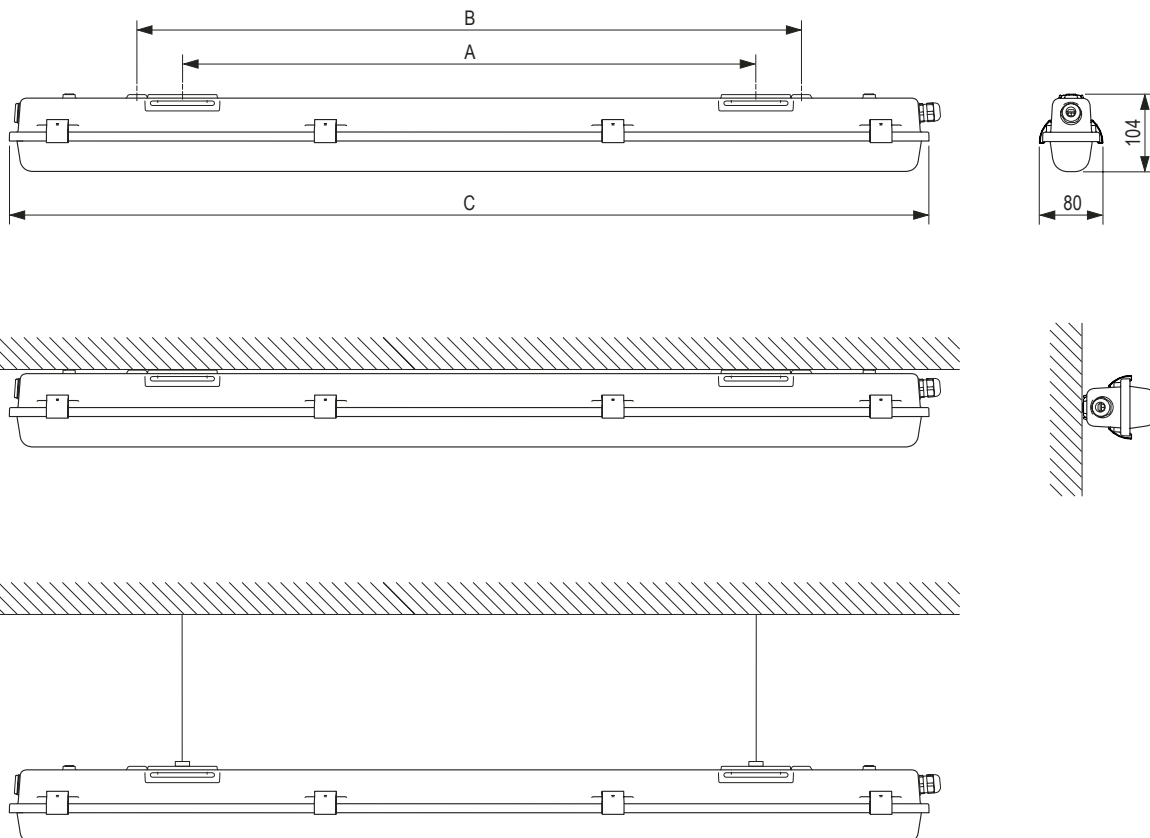
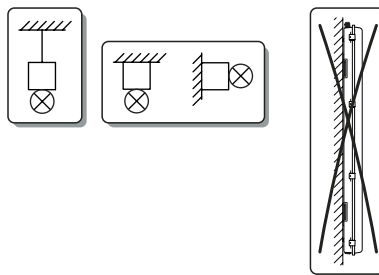

Maximum permissible number of electrical units in case of contemporary switch-on /
Maximale Anzahl der Leuchten bei gleichzeitigem Einschalten

Length/ Länge (mm)	Power Supply unit/ Transformator	Lamp family code/ Lampenfamilie	Circuit breaker / Leistungsschutzschalter			
			MCB B 10 A	MCB B 16 A	C10	C16
678	STD	2000 lm	12	24	24	40
678	DALI	2000 lm	12	20	20	34
1234	STD	4000 lm	12	24	24	40
1234	DALI	4000 lm	12	20	20	34
1534	STD	5000 lm	12	24	24	40
1534	DALI	5000 lm	12	20	20	34

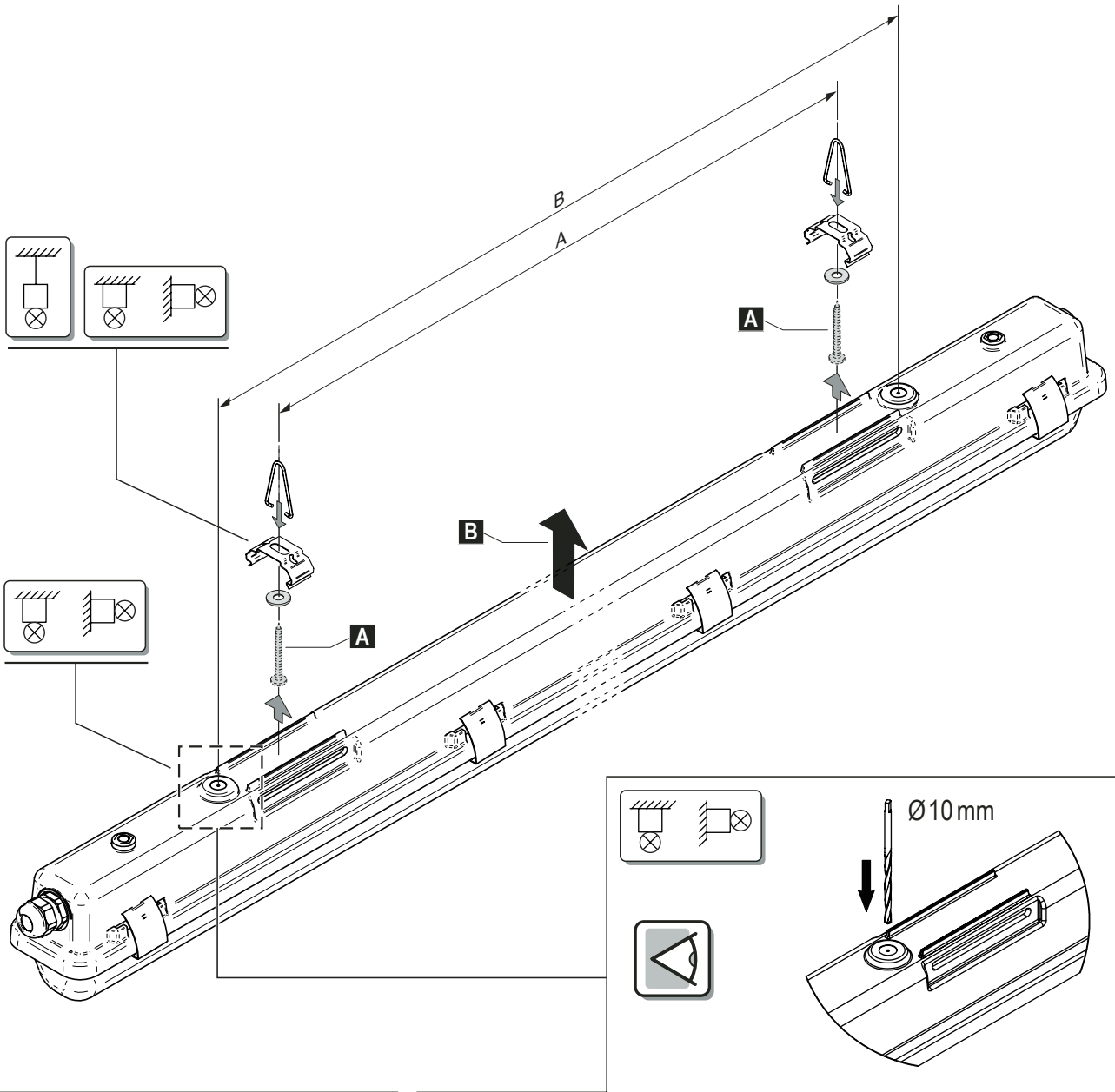

Option

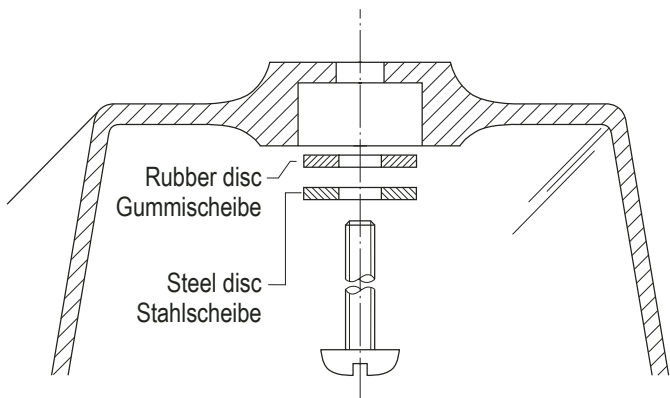
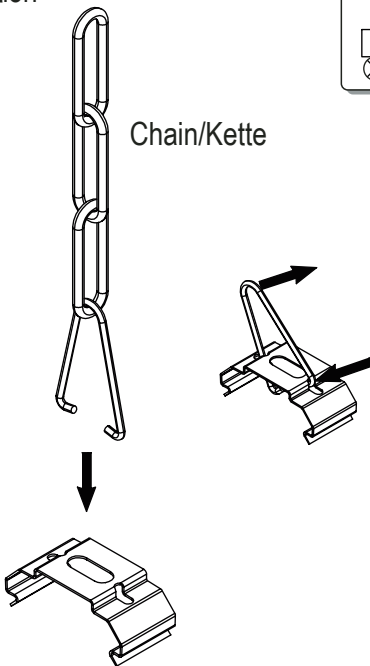

For use in civil defence shelter may attachment only with approved metal anchors for M6.
 Bei Einsatz in Schutzräumen des Zivilschutzes darf die Befestigung nur mit zugelassenen Metalldübeln für Schrauben M6 erfolgen.

2

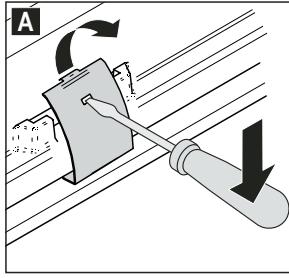
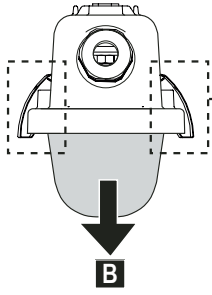

C Remove transportation lock
Transportsicherung entfernen

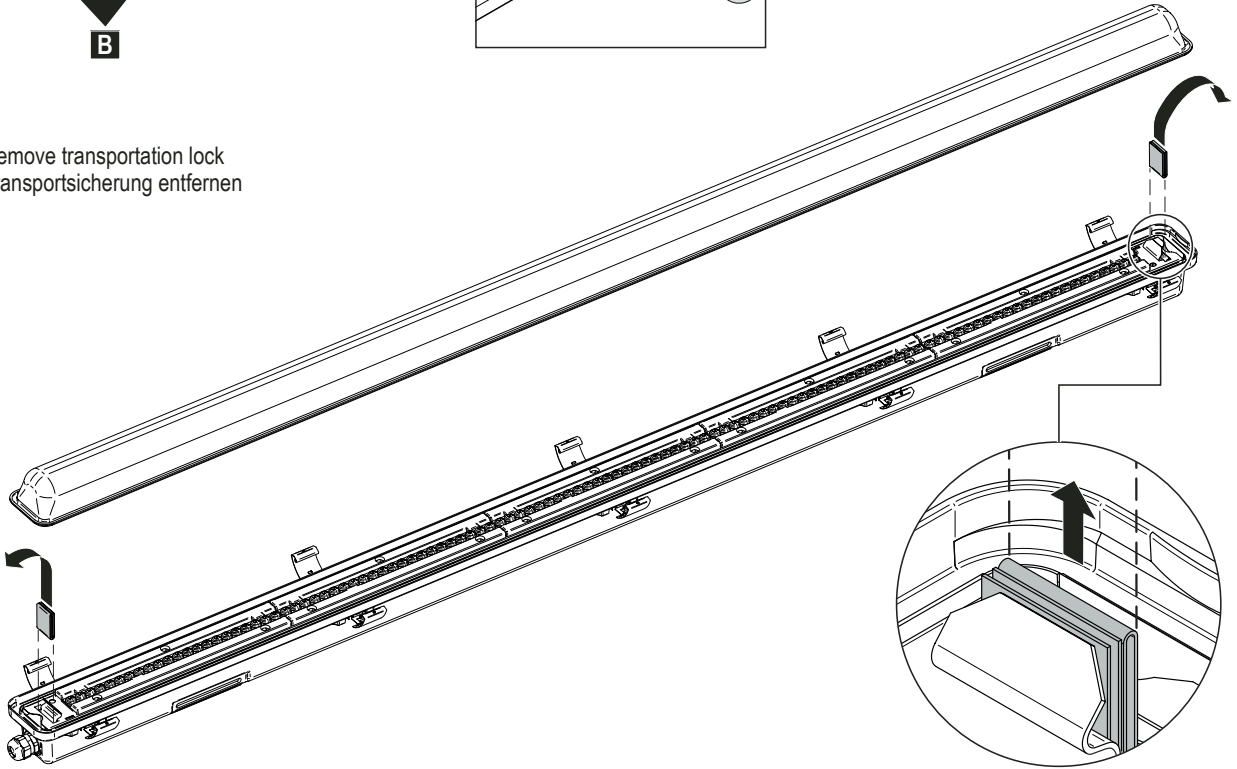

3

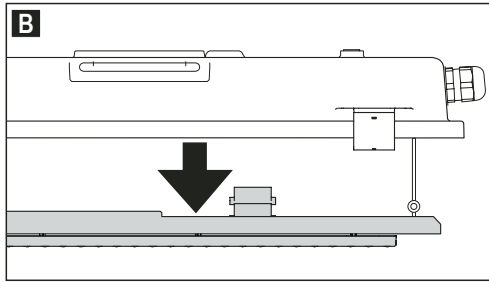
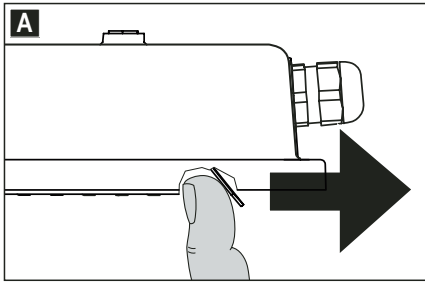

4

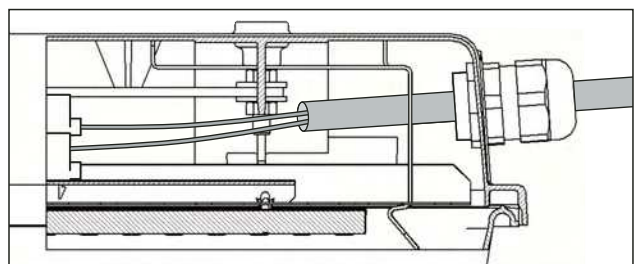
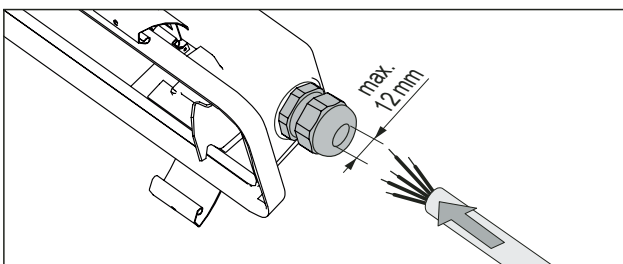
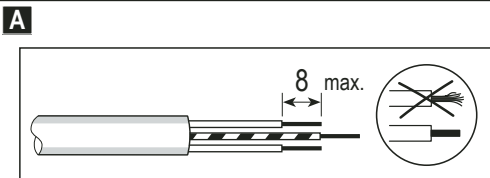

4

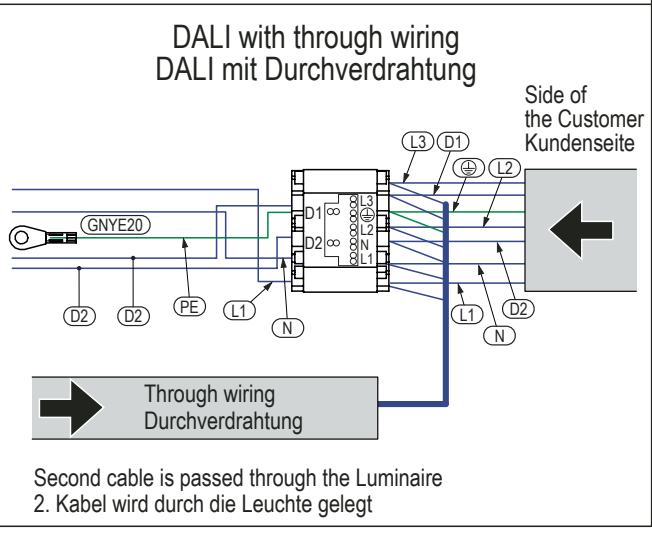
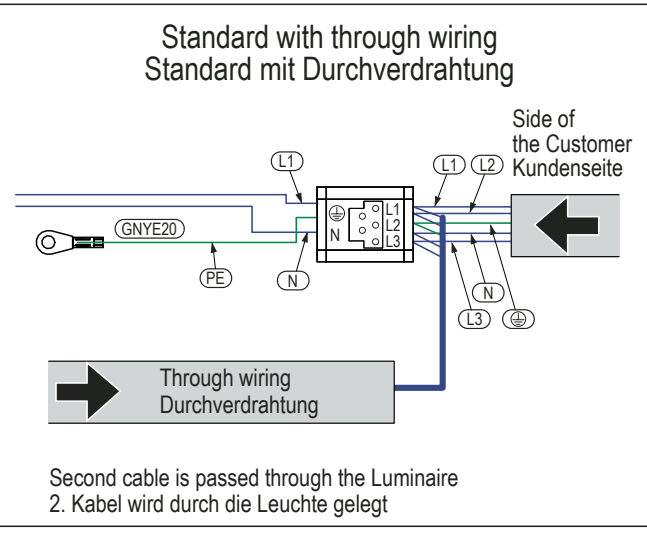
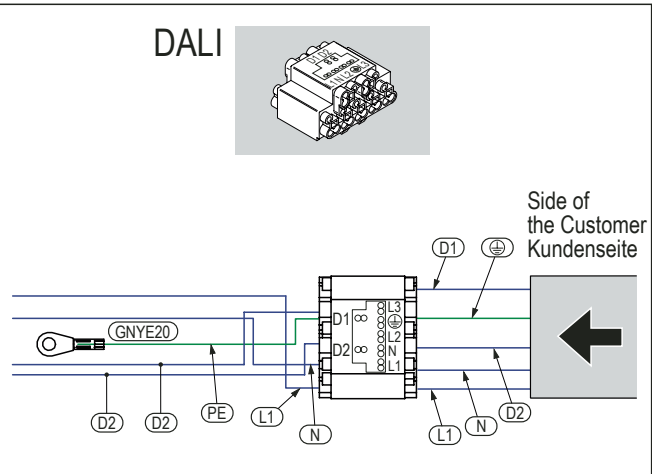
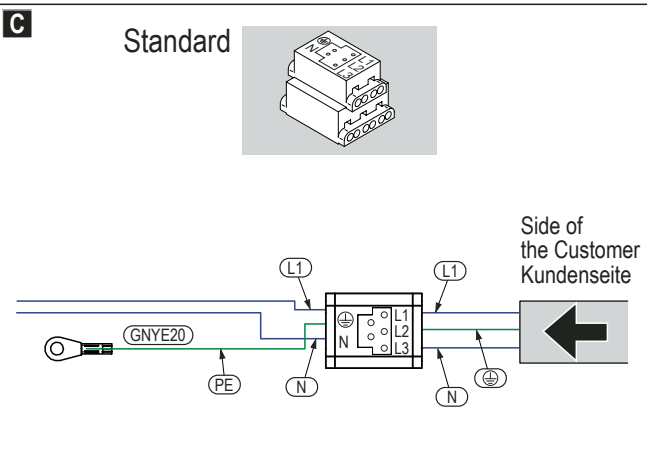
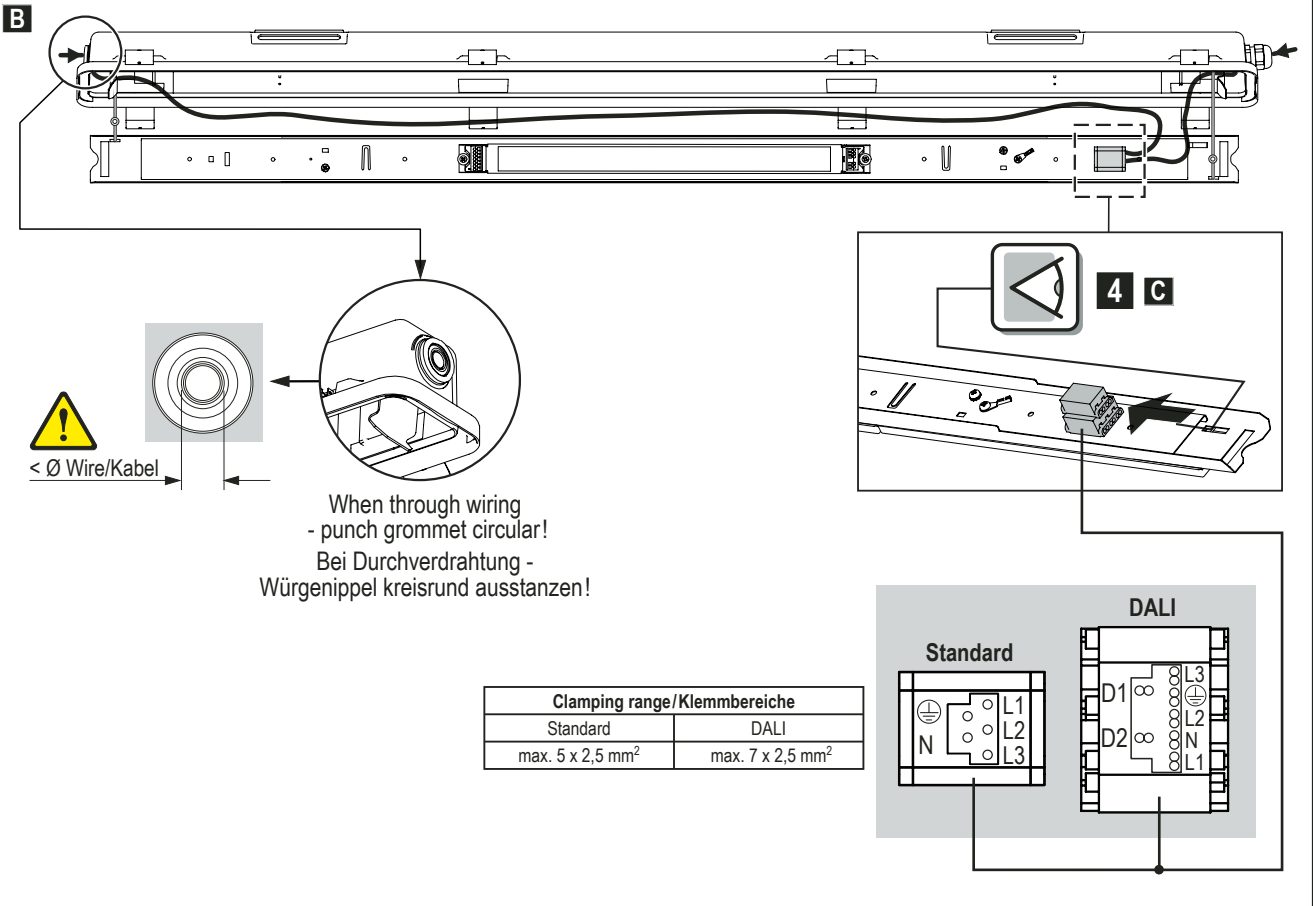

4

D Factory through wiring / Werksseitige Durchverdrahtung

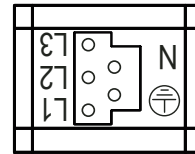
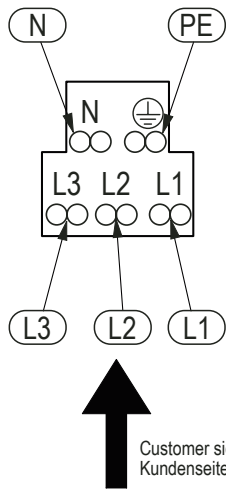

Using factory through wiring max. 3x16A on L1/L2/L3.
Luminaire connection via L1.

Bei werksseitiger Durchverdrahtung max. 3x16A über L1/L2/L3.
Leuchtenanschluss über L1.

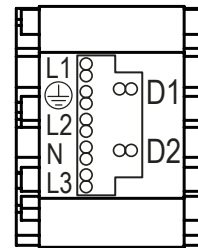
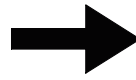
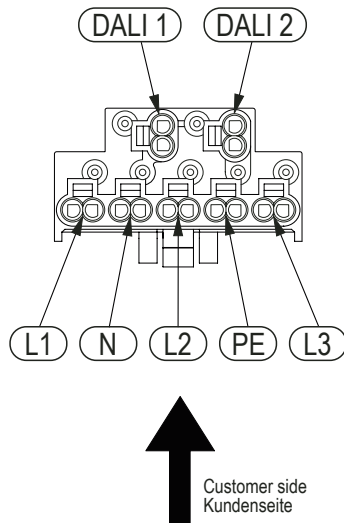

5

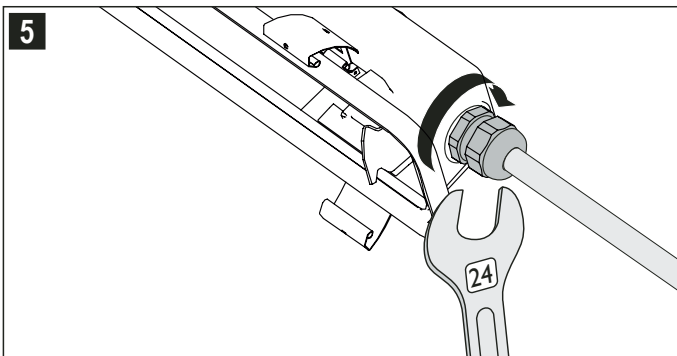

6



Make sure that PE is connected!
Erdungsverbindung sicherstellen!

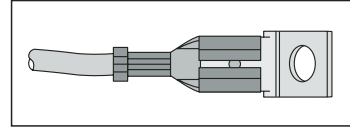
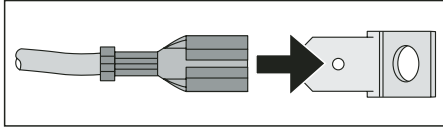

A

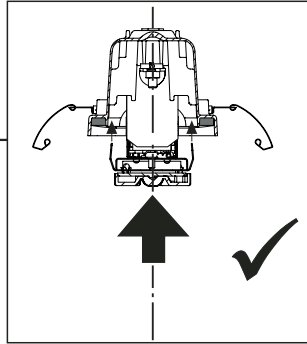
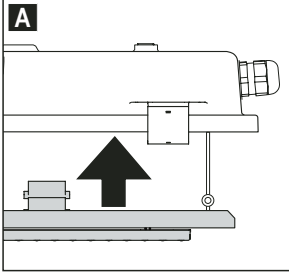

Gasket/Dichtung!

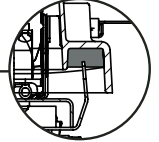
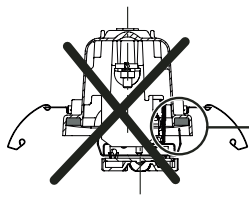

No/Nein

B

click

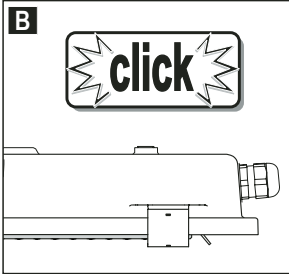

Cables/Leitungen!

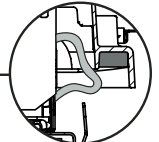
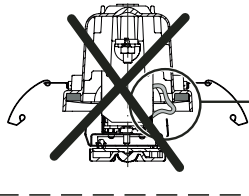

No/Nein

7

